

AFSX Speed Responsive Switch

0.1–1000 RPM.

NEC/CEC — Rated for:
Class I, Division 1 and 2, Groups C, D
Class II, Division 1 and 2, Groups E, F, G
Class III
NEMA 7CD, 9EFG

Applications

- For use in bulk material handling/processing systems to monitor speeds of:
 - Belt conveyors
 - Screw conveyors
 - Bucket elevators
 - Rotating machinery
- Used where alarm or computer interface capabilities are needed.
- For installation in:
 - Steel mills
 - Mining (ore and coal) operations
 - Grain handling
 - Chemical and plastic industries to protect elevators, feeders, and conveyors from speed related damage resulting from broken belts, overloads or belt slippage.
- For installation in mining and industrial areas where rugged control enclosures are needed for protection from falling ores, other heavy aggregates and from dripping water or hosedowns.
- Used in Class I and II areas where flammable vapors or highly combustible dusts are present.
- Designed to monitor material flow by sequencing the operation of multiple conveyors feeding a common bin or conveyor.
- Used as overspeed switches to detect motor overrun conditions. Pickup speed should be set above normal operating speeds. The output relay will energize if operating speed exceeds the set point.
- Used as underspeed switches to detect slipping belts, jammed conveyors or equipment and stalled motors: Pickup speed setting should be below normal operating speeds. The output relay will de-energize if operating speed falls below the set point.
- Used as zero speed switch: When speed approaches zero (0.1 RPM), the output relay will de-energize.

Features

- Signal range: three settings available (0.1-10 RPM; 1-100 RPM; 10-1000 RPM).
- Adjustable time delay (up to 45 seconds).
- Input power is applied to the speed responsive switch at all times. The switch then senses input shaft speed in either direction.
- When input shaft speed exceeds the pickup set point, the output relay is energized.
- If shaft speed falls below 80-85% of the pickup speed the relay will de-energize.
- Clockwise or counterclockwise rotation.
- Senses speed changes as slight as 1%.
- Operating temperatures are -45 °C to +65 °C (-49 °F to +149 °F).
- 3/4" NPT standard, two conduit openings.
- Radial load is 57 kilogram (125 pound) maximum at center of the key.
- Axial thrust load is 45 kilogram (100 pound) maximum.
- Driving torque required is one inch-pound maximum.
- Flexible coupling accessory allows up to 7.5° misalignment, high shock resistance and eliminates transmission of thrust loads.



Front

Back

Electrical Specifications

- Input voltage is 105-135 Vac, 50-60 Hz
- Output is a double pole, double throw relay rated 5 Amp resistive at 120 Vac, 5 Amp at 240 Vac, 5 Amp at 30 Vdc.
- Repeatability is +/-2% maximum at constant voltage and temperature.
- Power consumption is 3 watts maximum.
- Pulse sensor (solid state opto-electric infrared device) operating life is 25 years if constant operation is at maximum speed.
- Pickup speed is adjustable by set point potentiometer.
- Drop-out RPM will be 10-15% lower than pickup speed to account for normal fluctuations in actual operating RPM.
- If a signal is required within 1-15% of the normal operating speed, contact your local representative for presetting.

Standard Materials

- Housing: cast copperfree (4/10 of 1% max.) aluminum
- Shaft: stainless steel, 5/8" diameter
- #11 Woodruff key and hardware: stainless steel
- Flexible coupling: cast zinc
- Sleeve: neoprene with textile reinforcement

Standard Finishes

- Standard enclosure: shot peened

Optional Materials

- Housing: corrosion resistant epoxy powder coat

Options

- Epoxy powder coated switches, add suffix **-G1**.
- Mounting Bracket: **AFSA1, AFSB1, AFSB2, AFSB3**.
- Coupling guard: **AFSG1**.

AFSX Speed Responsive Switch

0.1–1000 RPM.

NEC/CEC — Rated for:
 Class I, Division 1 and 2, Groups C, D
 Class II, Division 1 and 2, Groups E, F, G
 Class III
 NEMA 7CD, 9EFG



Catalog Number

AFSX300

Optional Accessories

	Description	Catalog Number
	<p>Flexible Coupling</p> <p>This coupling will operate at up to a 7-1/2° axial misalignment with no significant life reduction. This unit features high shock resistance and eliminates transmission of lateral thrust from one shaft to the other (no end thrust).</p> <p>Sleeve: With axially molded internal teeth. Made of neoprene with textile reinforcement. Two end fittings grooved to mate with sleeve teeth. One fitting attached to each shaft.</p>	<p>AFSC1</p>
	<p>Stub Shaft</p> <p>76.2 mm (3") threaded one end, keyed other end. With jam nut and 3/16" key.</p>	<p>AFSS1</p>

CONTROLS: NEC/CEC EXPLOSIONPROOF CONVEYOR SWITCHES

Appleton

AFSX Speed Responsive Switch Mounting

0.1-1000 RPM.

NEC/CEC — Rated for:
 Class I, Division 1 and 2, Groups C, D
 Class II, Division 1 and 2, Groups E, F, G
 Class III
 NEMA 7CD, 9EFG

Dimensions in Millimeters (Inches) and Suggested Mounting Arrangement

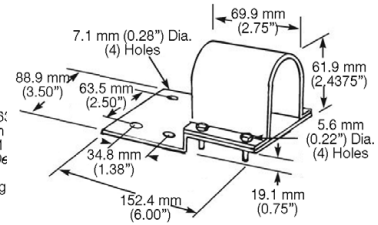
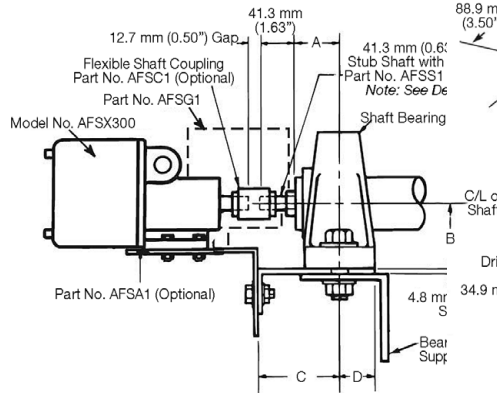
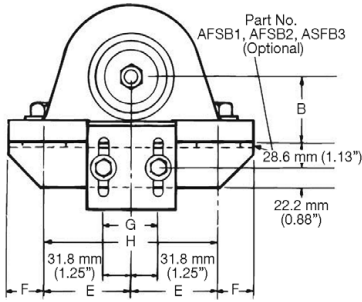

AFSG1 Coupling Guard

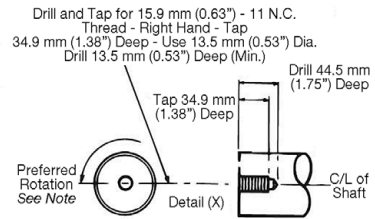

Bearing Bracket and Shim Plate Part #	Shaft Diameter	Dimensions in Millimeters (Inches)							
		A	B	C	D	E	F	G	H
AFSB1	36.6 (1.44)	31.8 - 50.8 (1.25 - 2.00)	47.8 - 54.1 (1.88 - 2.13)	79.5 (3.13)	28.7 (1.13)	68.3 (2.69)	46.0 (1.81)	49.2 x 25.4 (0.194 x 1.00)	14.3 x 33.3 (0.56 x 1.31)
AFSB2	49.3 - 62.0 (1.94 - 2.44)	38.1 - 65.0 (1.50 - 2.56)	57.2 - 76.2 (2.25 - 3.00)	95.3 (3.75)	41.4 (1.63)	93.7 (3.69)	49.3 (1.94)	49.2 x 25.4 (0.194 x 1.00)	20.6 x 50.8 (0.81 x 2.00)
AFSB3	74.7 - 100.1 (2.94 - 3.94)	76.2 - 95.3 (3.00 - 3.75)	79.5 - 104.9 (3.13 - 4.13)	114.3 (4.50)	55.6 (2.19)	122.2 (4.81)	68.3 (2.69)	49.2 x 25.4 (0.194 x 1.00)	27.0 x 65.1 (1.06 x 2.56)

Mounting Dimensions in Millimeters (inches)

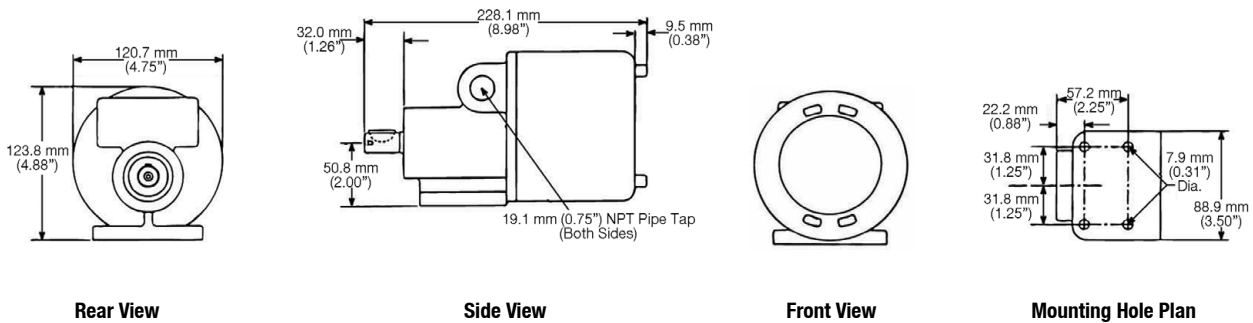

CONTROLS: NEC/CEC EXPLOSIONPROOF CONVEYOR SWITCHES

Appleton